

name HEB POWERLED 150/500

ref 150798 TEXTURED BLACK 3000K

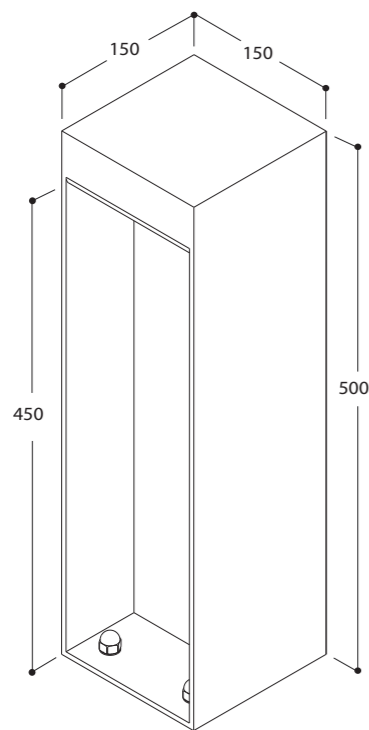

safe distance to object	- 0.1 m -
lamptype	HP LED 3 x 1.2W
fitting	/
watt	3 x 1.2W
voltage	230V - 50Hz - AC
symbol	
gear	Gear incorporated
ip/class	IP54 CLASS I
application	Exterior use
orientability	Floor mounted
dimmability	Not dimmable
weight	2

INSTALLATION AND MAINTENANCE INSTRUCTIONS IN VIEW OF THE MANUFACTURER'S GUARANTEE.
 1. THE CONNECTION AND TESTING OF THE DEVICES SHOULD ALWAYS BE PERFORMED BY A RECOGNIZED ELECTRICIAN.
 2. THESE LIGHTING DEVICES NEED TO BE INSTALLED, CONNECTED AND TESTED FOLLOWING THE OFFICIAL NATIONAL INSTRUCTION GUIDE FOR ELECTRICAL INSTALLATIONS (BELGIUM, A.R.E.I., GERMANY: DIN VDE 0100 TEIL 559 A2, ...; THIS ENUMERATION IS JUST AN INDICATION)
 3. THIS TECHNICAL ENCLOSURE NEEDS TO BE ADDED TO THE GENERAL SALES CONDITION OF THE TAL N.V.
 4. THE ELECTRO TECHNICIAN IS RESPONSIBLE TO USE BALLASTS, TRANSFORMERS,...WHICH MEET THE VALID CE AND EMC RULES.
 5. ALWAYS REPLACE THE LAMP (-S) WITH UTMOST CAUTIOUSNESS, THE LAMP (-S) IS (ARE) VERY FRAGILE.
 6. ATTENTION: NEVER REPLACE THE LAMP WITH BARE HANDS, ALWAYS USE A CLOTH!

ACCESSORIES

ref 260991 resp. GROUND PIN + LARGE FOOT

① Remove backplate

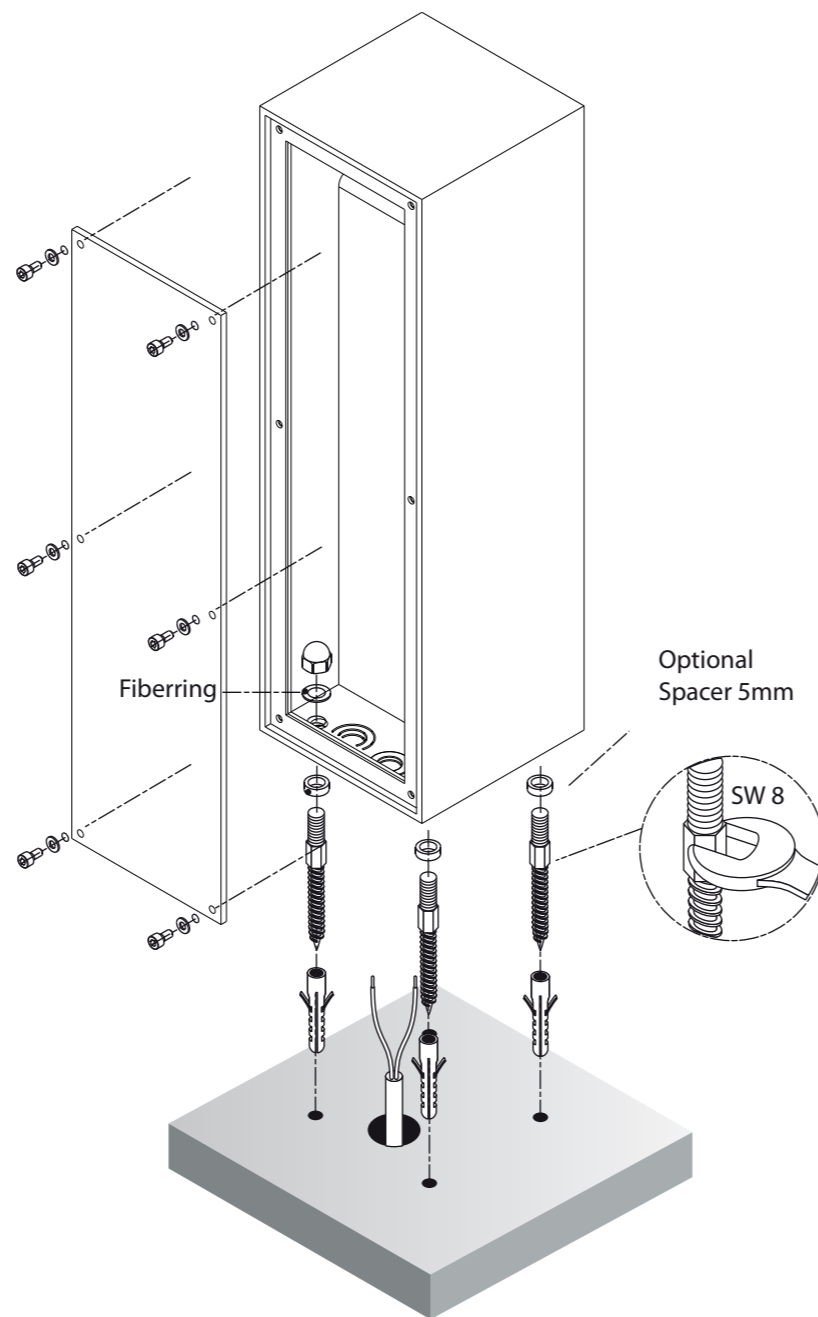

② Make waterproof connection.

③ Close backplate.

